

Individual address setting chart
(for master or shadow mode sounders)

1 = DIL switch in the OFF (open) position
0 = DIL switch in the ON (closed) position

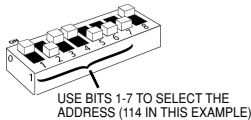

DIL POSITION 1234567	DIL POSITION 1234567	DIL POSITION 1234567	DIL POSITION 1234567
1 1000000	33 1000010	65 1000001	97 1000011
2 0100000	34 0100010	66 0100001	98 0100011
3 1100000	35 1100010	67 1100001	99 1100011
4 0010000	36 0010010	68 0010001	100 0010011
5 1010000	37 1010010	69 1010001	101 1010011
6 0110000	38 0110010	70 0110001	102 0110011
7 1110000	39 1110010	71 1110001	103 1110011
8 0001000	40 0001010	72 0001001	104 0001011
9 1001000	41 1001010	73 1001001	105 1001011
10 0101000	42 0101010	74 0101001	106 0101011
11 1101000	43 1101010	75 1101001	107 1101011
12 0011000	44 0011010	76 0011001	108 0011011
13 1011000	45 1011010	77 1011001	109 1011011
14 0111000	46 0111010	78 0111001	110 0111011
15 1111000	47 1111010	79 1111001	111 1111011
16 0000100	48 0000110	80 0000101	112 0000111
17 1000100	49 1000110	81 1000101	113 1000111
18 0100100	50 0100110	82 0100101	114 0100111
19 1100100	51 1100110	83 1100101	115 1100111
20 0010100	52 0010110	84 0010101	116 0010111
21 1010100	53 1010110	85 1010101	117 1010111
22 0110100	54 0110110	86 0110101	118 0110111
23 1110100	55 1110110	87 1110101	119 1110111
24 0001100	56 0001110	88 0001101	120 0001111
25 1001100	57 1001110	89 1001101	121 1001111
26 0101100	58 0101110	90 0101101	122 0101111
27 1101100	59 1101110	91 1101101	123 1101111
28 0011100	60 0011110	92 0011101	124 0011111
29 1011100	61 1011110	93 1011101	125 0111111
30 0111100	62 0111110	94 0111101	126 0111111
31 1111100	63 1111110	95 1111101	
32 0000010	64 0000001	96 0000011	

Group addressing: This feature allows any number of individually addressed 'master' sounders to be allocated an additional 'group' address to activate the sounders simultaneously. Sounders will continue to respond to their own 'master' address and report back their status as appropriate. A group address can be any address between 112-126 and is set using the Group Address DIL switches (see right and diagram on pg 2):-

Group addressing chart

DIL POSITION 1234	DIL POSITION 1234
112 1111	120 1110
113 0111	121 0110
114 1011	122 1010
115 0011	123 0010
116 1101	124 1100
117 0101	125 0100
118 1001	126 1000
119 0001	OFF 0000

BF330CASR/DR ADDRESSABLE SOUNDER
BF333CASR/DR ADDRESSABLE SOUNDER/BEACON



This sounder is designed for use with Apollo XP95, Series 90, Xplorer and/or Discovery compatible fire alarm control panels.

It can be surface mounted onto an appropriate interior building surface using the back box provided.

Dependent on the model purchased, the sounder may have a built-in flashing beacon that flashes once a second when in evacuate or alert mode.

BF330CASR
ADDRESSABLE SOUNDER & SHALLOW BASE

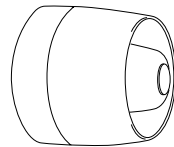

Supply voltage 17-28V DC
Typical quiescent current @ 24V 800µA
Typical alarm current @ 24V 7.5mA
Sound output @ 1m 100dB (high); 94dB (low)
Weight 160g
Protection IP43

BF330CADR
ADDRESSABLE SOUNDER & DEEP BASE

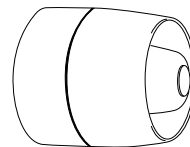

Supply voltage 17-28V DC
Typical quiescent current @ 24V 800µA
Typical alarm current @ 24V 7.5mA
Sound output @ 1m 100dB (high); 94dB (low)
Weight 195g
Protection IP65

BF333CASR
ADDRESSABLE SOUNDER/BEACON & SHALLOW BASE

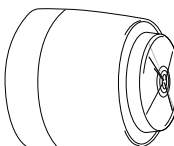

Supply voltage 17-28V DC
Typical quiescent current @ 24V 800µA
Typical alarm current @ 24V 8mA
Sound output @ 1m 100dB (high); 94dB (low)
Weight 205g
Protection IP43

BF333CADR
ADDRESSABLE SOUNDER/BEACON & DEEP BASE

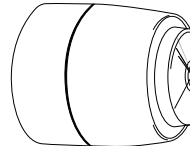

Supply voltage 17-28V DC
Typical quiescent current @ 24V 800µA
Typical alarm current @ 24V 8mA
Sound output @ 1m 100dB (high); 94dB (low)
Weight 230g
Protection IP65

Individual address setting chart
(for master or shadow mode sounders)

1 = DIL switch in the OFF (open) position
0 = DIL switch in the ON (closed) position



DIL POSITION 1234567	DIL POSITION 1234567	DIL POSITION 1234567	DIL POSITION 1234567
1 1000000	33 1000010	65 1000001	97 1000011
2 0100000	34 0100010	66 0100001	98 0100011
3 1100000	35 1100010	67 1100001	99 1100011
4 0010000	36 0010010	68 0010001	100 0010011
5 1010000	37 1010010	69 1010001	101 1010011
6 0110000	38 0110010	70 0110001	102 0110011
7 1110000	39 1110010	71 1110001	103 1110011
8 0001000	40 0001010	72 0001001	104 0001011
9 1001000	41 1001010	73 1001001	105 1001011
10 0101000	42 0101010	74 0101001	106 0101011
11 1101000	43 1101010	75 1101001	107 1101011
12 0011000	44 0011010	76 0011001	108 0011011
13 1011000	45 1011010	77 1011001	109 1011011
14 0111000	46 0111010	78 0111001	110 0111011
15 1111000	47 1111010	79 1111001	111 1111011
16 0000100	48 0000110	80 0000101	112 0000111
17 1000100	49 1000110	81 1000101	113 1000111
18 0100100	50 0100110	82 0100101	114 0100111
19 1100100	51 1100110	83 1100101	115 1100111
20 0010100	52 0010110	84 0010101	116 0010111
21 1010100	53 1010110	85 1010101	117 1010111
22 0110100	54 0110110	86 0110101	118 0110111
23 1110100	55 1110110	87 1110101	119 1110111
24 0001100	56 0001110	88 0001101	120 0001111
25 1001100	57 1001110	89 1001101	121 1001111
26 0101100	58 0101110	90 0101101	122 0101111
27 1101100	59 1101110	91 1101101	123 1101111
28 0011100	60 0011110	92 0011101	124 0011111
29 1011100	61 1011110	93 1011101	125 0111111
30 0111100	62 0111110	94 0111101	126 0111111
31 1111100	63 1111110	95 1111101	
32 0000010	64 0000001	96 0000011	

Group addressing: This feature allows any number of individually addressed 'master' sounders to be allocated an additional 'group' address to activate the sounders simultaneously. Sounders will continue to respond to their own 'master' address and report back their status as appropriate. A group address can be any address between 112-126 and is set using the Group Address DIL switches (see right and diagram on pg 2):-

Group addressing chart

DIL POSITION 1234	DIL POSITION 1234
112 1111	120 1110
113 0111	121 0110
114 1011	122 1010
115 0011	123 0010
116 1101	124 1100
117 0101	125 0100
118 1001	126 1000
119 0001	OFF 0000

BF330CASR/DR ADDRESSABLE SOUNDER
BF333CASR/DR ADDRESSABLE SOUNDER/BEACON



This sounder is designed for use with Apollo XP95, Series 90, Xplorer and/or Discovery compatible fire alarm control panels.

It can be surface mounted onto an appropriate interior building surface using the back box provided.

Dependent on the model purchased, the sounder may have a built-in flashing beacon that flashes once a second when in evacuate or alert mode.

BF330CASR
ADDRESSABLE SOUNDER & SHALLOW BASE

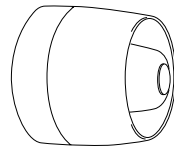

Supply voltage 17-28V DC
Typical quiescent current @ 24V 800µA
Typical alarm current @ 24V 7.5mA
Sound output @ 1m 100dB (high); 94dB (low)
Weight 160g
Protection IP43

BF330CADR
ADDRESSABLE SOUNDER & DEEP BASE

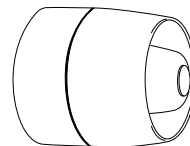

Supply voltage 17-28V DC
Typical quiescent current @ 24V 800µA
Typical alarm current @ 24V 7.5mA
Sound output @ 1m 100dB (high); 94dB (low)
Weight 195g
Protection IP65

BF333CASR
ADDRESSABLE SOUNDER/BEACON & SHALLOW BASE

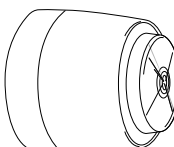

Supply voltage 17-28V DC
Typical quiescent current @ 24V 800µA
Typical alarm current @ 24V 8mA
Sound output @ 1m 100dB (high); 94dB (low)
Weight 205g
Protection IP43

BF333CADR
ADDRESSABLE SOUNDER/BEACON & DEEP BASE

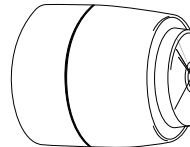

Supply voltage 17-28V DC
Typical quiescent current @ 24V 800µA
Typical alarm current @ 24V 8mA
Sound output @ 1m 100dB (high); 94dB (low)
Weight 230g
Protection IP65

INSTALLATION

THE SYSTEM MUST BE COMPLETELY POWERED DOWN PRIOR TO INSTALLATION.

MOUNTING THE SOUNDER BASE

Depending on the model purchased, the sounder will have a shallow or a deep base.

Shallow bases are ideal for applications where the loop cable is buried into the wall as they have a large access hole through which the cable can be brought. **Deep bases** include an additional side cover that can be optionally removed to accept cabling that runs along the surface of the wall.

All bases feature a 'bayonet' fixing arrangement for ease of installation.

WIRING

Incoming and outgoing loop cables should be connected to the sounder's connector block as shown. Note, these connections are polarity sensitive.

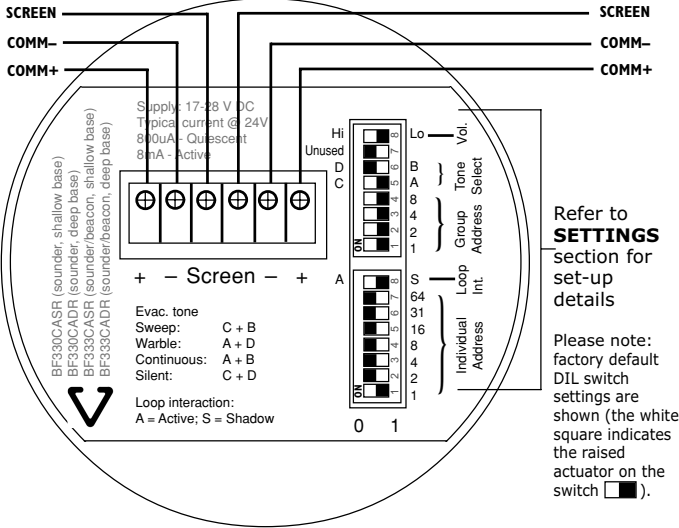

SETTINGS

Evacuate tones

Three selectable Evacuate tones are available:-

- Continuous - a single frequency tone.
 - Warble - alternates between two tones.
 - Sweep - a repeating stepped increase in frequency from a low to high tone.
- The desired tone can be set using the Tone Select DIL switches as shown:-

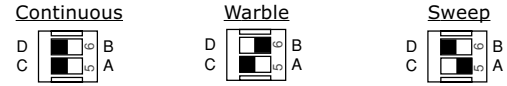

Alert tone

The sounder has a non-adjustable pulsed (on/off) single frequency Alert tone.

Volume adjust

The sounder's output volume can be set to a high setting (typically 100dB @ 1metre) or a low setting (typically 94dB @ 1metre) using the Vol. DIL switch, as shown. The default volume setting is High.

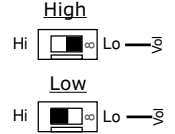

Address setting

The main mode of addressing this sounder is Individual Addressing. Optional 'Shadow' and 'Group' addressing modes are also available.

Individual Addressing: Each sounder will normally have an individual address assigned to it. This can be any address from 1-126 (if group mode is not utilised) or 1 -111 (if group mode is utilised). The sounder's address can be set using the appropriate DIL switch setting - see chart overleaf. Provided the sounder's Loop Int. DIL switch is set to 'A' (see below) this unique address will allow the sounder to operate as an ordinary addressable device, listening and responding to commands from the fire panel and reporting its status back for monitoring purposes.

Master and Slave Operation: A special feature of this range of sounders allows multiple 'shadow' sounders to share the same address as a nominated 'master' sounder. If utilising this feature, one sounder must be set up as a master sounder with all other same addressed sounders set up as shadow sounders. This can be done using the Loop Int. DIL switch as shown below right. All shadow sounders will respond to commands from the fire panel in the same way as the master sounder but they will not report back their status (i.e. they will not be monitored).

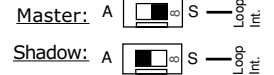

INSTALLATION

THE SYSTEM MUST BE COMPLETELY POWERED DOWN PRIOR TO INSTALLATION.

MOUNTING THE SOUNDER BASE

Depending on the model purchased, the sounder will have a shallow or a deep base.

Shallow bases are ideal for applications where the loop cable is buried into the wall as they have a large access hole through which the cable can be brought. **Deep bases** include an additional side cover that can be optionally removed to accept cabling that runs along the surface of the wall.

All bases feature a 'bayonet' fixing arrangement for ease of installation.

WIRING

Incoming and outgoing loop cables should be connected to the sounder's connector block as shown. Note, these connections are polarity sensitive.

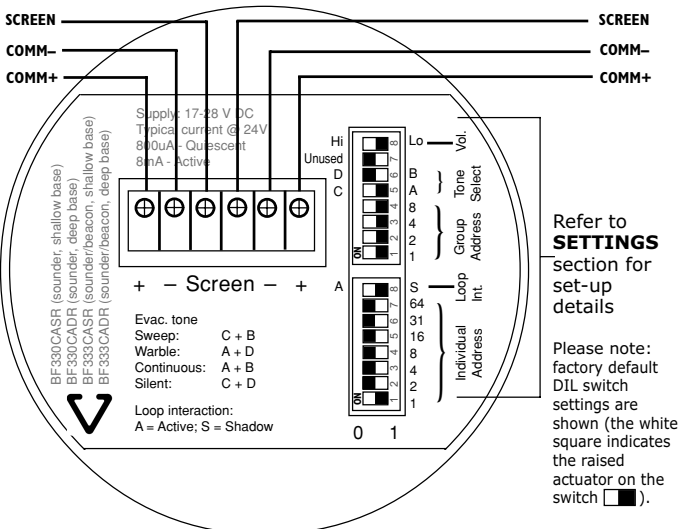

SETTINGS

Evacuate tones

Three selectable Evacuate tones are available:-

- Continuous - a single frequency tone.
 - Warble - alternates between two tones.
 - Sweep - a repeating stepped increase in frequency from a low to high tone.
- The desired tone can be set using the Tone Select DIL switches as shown:-



Alert tone

The sounder has a non-adjustable pulsed (on/off) single frequency Alert tone.

Volume adjust

The sounder's output volume can be set to a high setting (typically 100dB @ 1metre) or a low setting (typically 94dB @ 1metre) using the Vol. DIL switch, as shown. The default volume setting is High.



Address setting

The main mode of addressing this sounder is Individual Addressing. Optional 'Shadow' and 'Group' addressing modes are also available.

Individual Addressing: Each sounder will normally have an individual address assigned to it. This can be any address from 1-126 (if group mode is not utilised) or 1 -111 (if group mode is utilised). The sounder's address can be set using the appropriate DIL switch setting - see chart overleaf. Provided the sounder's Loop Int. DIL switch is set to 'A' (see below) this unique address will allow the sounder to operate as an ordinary addressable device, listening and responding to commands from the fire panel and reporting its status back for monitoring purposes.

Master and Slave Operation: A special feature of this range of sounders allows multiple 'shadow' sounders to share the same address as a nominated 'master' sounder. If utilising this feature, one sounder must be set up as a master sounder with all other same addressed sounders set up as shadow sounders. This can be done using the Loop Int. DIL switch as shown below right. All shadow sounders will respond to commands from the fire panel in the same way as the master sounder but they will not report back their status (i.e. they will not be monitored).

